

# Assembly and operating instructions

## Guided type fall arrester: GÜFA 5 and GÜFA Flexx with fixed guide Type: GÜFA

**US/CAN/AUS/NZL**

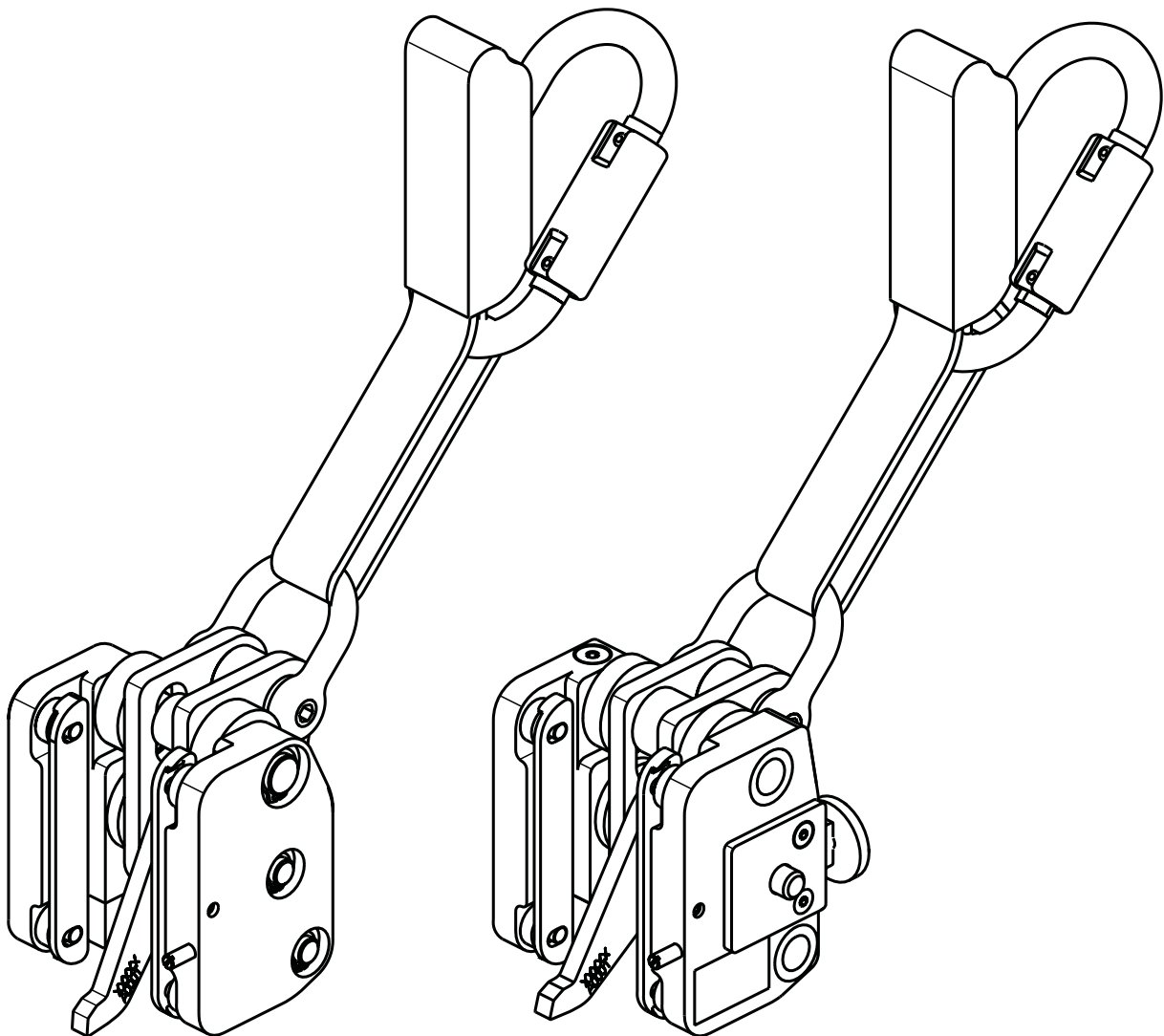

77580

77582

## Content

General.....	3
Performance data of the climbing arrester system.....	4
Intended use .....	5
Safety provisions .....	7
Assembly .....	8
Inspections.....	13
Inspection before use .....	14
Use of the Guided type fall arrester.....	15
Operating instructions and training .....	16
Maintenance, cleaning, decommissioning, dismantling and disposal .....	18
Warranty and liability .....	19
Documentation .....	20
EU Declaration of Conformity .....	23



### DANGER

The danger warning indicates a hazard with a high degree of risk which, if not avoided, may result in death or serious injury.



### CAUTION

The caution indicates a hazard with a low risk level which, if not avoided, may result in minor or moderate injury or damage to property up to and including destruction of the installation.



### NOTICE

Notice stands for requirements and important information which must be particularly observed.

## General

The following operating instructions comply with DIN EN 365 and DIN EN 353-1. It contains the assembly instructions and information brochure.

## Scope of application

These operating instructions apply to the GÜFA climbing arrester system, including the fixed ladder with centre rail (single rail ladder).

When using the GÜFA Flexx with the single-rail mast ladder, the corresponding instructions "Single-rail mast ladder assembly and user instructions" must also be observed.

When using the GÜFA Flexx with the single-rail ladder with retractable rungs, the corresponding instructions "Assembly instructions for single-rail ladders with retractable rungs" must also be observed.

## Terms

### Fixed guide,

hereinafter referred to as the **arrester rail**.

Subsystem consisting of a permanently installed guide for the guided type fall arrester.

### Live fall arrester,

hereinafter referred to as the **guided type fall arrester**.

Subsystem consisting of an automatically blocking, live fall arrester and a connector or a means of connection with attached connector.

### Live fall arrester including fixed guide

hereinafter referred to as the **climbing arrester system**.

System consisting of arrester rail and guided type fall arrester.

A fall-absorbing function may be present in the interaction between the guided type fall arrester and the arrester rail, or a fall arrester may be inserted in the connector or in the arrester rail.

## Full body harness

Holding device for the body primarily for containment purposes, i.e. a component of a fall arrester system. The full body harness may consist of webbing, fittings, buckles or other components arranged and assembled in such a way that they provide full body support to a person and hold the wearer during a fall or after a fall arrest (DIN EN 363).

## Fall arrester (energy absorber)

Part or component of a fall arrest system designed to convert the kinetic energy generated during a fall.

## Overview of standards

The guided type fall arrester and the components of personal protective equipment used in conjunction with it must comply with the following standards and inspection specifications:

Standard	Edition	Name of the item
ANSI/ASSE Z359.16		Personal equipment for work at height Manufacturing requirements for fall-arrest devices
ANSI/ASSE Z359.2		Minimum Requirements for a Comprehensive Managed Fall Protection Program Occupational Safety and Health Standards - Equipment - Standard Number: 1910.140 - Title: Personal fall protection systems
ANSI/ASSE Z359.11		Safety Requirements for Full Body Harnesses
AS 1891.3:2020		Personal equipment for work at height Manufacturing requirements for fall-arrest devices
AS 1891.3 AMD 1:2021		Personal equipment for work at height, Part 3: Manufacturing requirements for fall-arrest devices
CSA Z259.2.4:2015-06-01		Fall arresters and vertical rigid rails
DIN EN 363	2019	Personal fall protection equipment – Personal fall protection systems
DIN EN 365	2004	Personal protective equipment against falls from a height - General requirements for instructions for use, maintenance, periodic examination, repair, marking and packaging
DIN EN 365 Revision 1	2007	Corrigenda DIN EN 365 (2004)

### Inspection centre

The authority involved in the type examination:

DEKRA Testing and Certification GmbH  
Dinnendahlstrasse 9  
44809 Bochum, Germany  
CE 0158

### Performance data of the climbing arrester system

- permissible number of persons: 1 Person
- maximum weight of the user (including clothing and equipment): 150 kg
- Minimum weight of the user (including clothing and equipment): 50 kg
- min. operating temperature: -30 °C
- Do not use the guided type fall arrester

in the workstation position. A separate system must be implemented for use in working position.

Depending on the application and the ambient conditions, the following performance data of the climbing arrester system result:

- **maximum arrest force according to DIN EN 353-1:2018 forces according to ANSI/ASSE Z359.16**  
- maximum arrest force 1,800 pounds (8 kN)  
- average arrest force 1,350 pounds (6 kN)
- **max. arresting distance H = 1.0 m**

The operator of the system must affix an appropriate warning notice to the structural installation, which informs the user beyond doubt of the safety distance.

For ANSI ANSI/ASSE Z359.16

Allowable number of climber on the system maximum 3 persons with a minimum distance of 3 m

### Intended use

The scope of application of the climbing arrester system results from the requirements of the legislator, the industrial employers' liability insurance associations and the German statutory accident insurance (DGUV). Other regional regulations may have to be taken into account for the application.

The intended use of the climbing arrester system can be found in these instructions. The climbing arrester system must not be used

with a back protection system. The climbing arrester system necessarily takes effect during use and thus offers optimum protection and the greatest possible freedom of movement for the person climbing.

When used as intended, it is possible to climb predominantly stationary vertical (90°) fixed ladder or step-iron gangways with practically unlimited climbing height. The following deviations from the vertical are permissible: 15° tilt forward

A combination of guided type fall arrester system within a caged ladder is not allowed. The Guided type fall arrester may only be used with the following tested arrester rails from MUNK GmbH:

Arrester rail with connection strap	Single-rail ladder	Single-rail mast ladder
Steel design <ul style="list-style-type: none"> <li>▪ 77530 - 1.40 m</li> <li>▪ 77531 - 1.96 m</li> <li>▪ 77532 - 2.80 m</li> </ul>	Steel design <ul style="list-style-type: none"> <li>▪ 77533 - 1.40 m</li> <li>▪ 77534 - 1.96 m</li> <li>▪ 77535 - 2.80 m</li> </ul>	
Stainless steel design <ul style="list-style-type: none"> <li>▪ 77550 - 1.40 m</li> <li>▪ 77551 - 1.96 m</li> <li>▪ 77552 - 2.80 m</li> </ul>	Stainless steel design <ul style="list-style-type: none"> <li>▪ 77553 - 1.40 m</li> <li>▪ 77554 - 1.96 m</li> <li>▪ 77555 - 2.80 m</li> </ul>	
Aluminium design <ul style="list-style-type: none"> <li>▪ 77059 - 1.40 m</li> <li>▪ 77058 - 1.96 m</li> <li>▪ 77057 - 2.80 m</li> </ul>	Aluminium design <ul style="list-style-type: none"> <li>▪ 77056 - 1.40 m</li> <li>▪ 77080 - 1.96 m</li> <li>▪ 77055 - 2.80 m</li> <li>▪ 725.001.7 (Special profile for single rail folding ladder)</li> </ul>	Aluminium design <ul style="list-style-type: none"> <li>▪ 77431 - 1.12 m</li> <li>▪ 77432 - 1.96 m</li> </ul>



#### NOTICE

These instructions must be kept together with the guided type fall arrester.



#### DANGER

##### Life-threatening danger

Observe and follow the instructions in this manual.

Improper use of the guided type fall arrester is prohibited. Only the equipment manufacturer, or persons or entities authorized in writing by the manufacturer, shall make repairs to equipment. Do not use combinations of components or subsystems, or both, which may affect or interfere with the safe function of each other. The consequences of improperly using the device, not following instructions or markings may cause serious injury or death. The equipment shall not be used in ways other than intended and described in this manual. When using the equipment around moving machinery and electrical hazards or near sharp edges and abrasive surfaces.

## Explanation of the marking on the climbing arrester system



Observe the manufacturer's operating and installation instructions before commissioning the climbing arrester system.

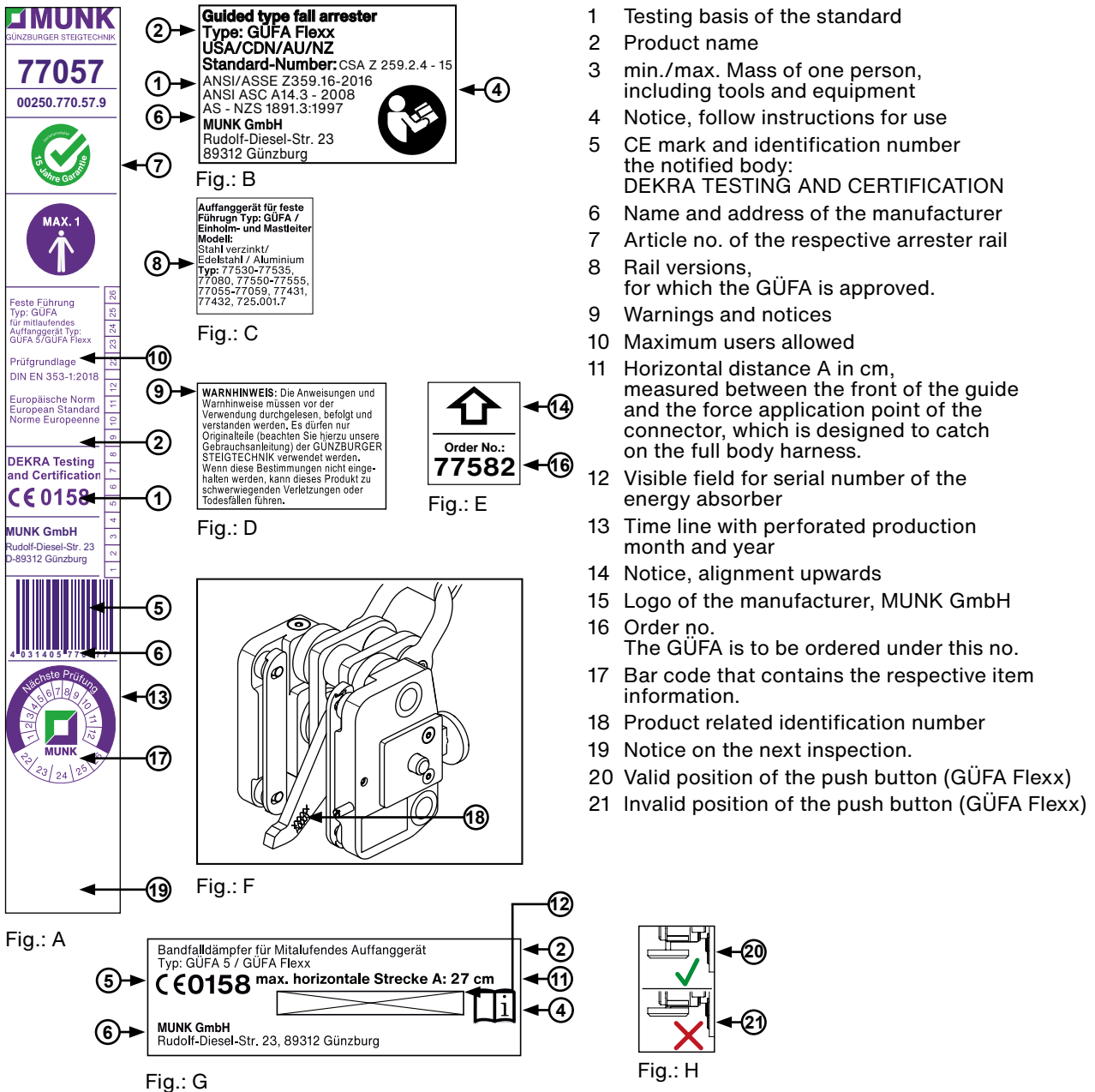

- 1 Testing basis of the standard
- 2 Product name
- 3 min./max. Mass of one person, including tools and equipment
- 4 Notice, follow instructions for use
- 5 CE mark and identification number the notified body: DEKRA TESTING AND CERTIFICATION
- 6 Name and address of the manufacturer
- 7 Article no. of the respective arrester rail
- 8 Rail versions, for which the GÜFA is approved.
- 9 Warnings and notices
- 10 Maximum users allowed
- 11 Horizontal distance A in cm, measured between the front of the guide and the force application point of the connector, which is designed to catch on the full body harness.
- 12 Visible field for serial number of the energy absorber
- 13 Time line with perforated production month and year
- 14 Notice, alignment upwards
- 15 Logo of the manufacturer, MUNK GmbH
- 16 Order no. The GÜFA is to be ordered under this no.
- 17 Bar code that contains the respective item information.
- 18 Product related identification number
- 19 Notice on the next inspection.
- 20 Valid position of the push button (GÜFA Flexx)
- 21 Invalid position of the push button (GÜFA Flexx)

- Fig. A: Shown on the side of the arrester rail  
 Fig. B: Shown on the back of guided type fall arrester  
 Fig. C: Shown on the side of the guided type fall arrester  
 Fig. D: Shown on the side of the guided type fall arrester  
 Fig. E: Shown on the back of guided type fall arrester  
 Fig. F: GÜFA Flexx safety-runner with notice to the markings  
 Fig. G: Shown on the belt arrester element  
 Fig. H: Shown on the top of the guided type fall arrester (GÜFA Flexx)

## Safety provisions

### General safety instructions

- The instructions shall be provided to the users.
- Only persons who are familiar with the basic regulations on work safety and accident prevention may use the system.
- The user must have read the operating instructions.
- The user must know and follow the relevant accident prevention and safety regulations and the workplace directives.
- Harnesses, seat belts or older type B safety harnesses which only partially enclose the body shall not be used.
- The guided type fall arrester and full body harness are part of the personal protective equipment and are only designed for the intended use.
- The climbing arrester system may only be used by persons who have been instructed in its safe use and have the appropriate knowledge.
- Climbing under physical conditions and constitutions that impair the safety of the user in normal and emergency situations (e.g. influence of alcohol/ medication, dizziness, fear of heights, etc.) is not permitted.
- Before each use, visually check the guided type fall arrester and the PPE used for proper condition, as well as the insertion and removal points of the arrester rail (see p. 13).
- Check the complete climbing arrester system for damage before each use. Damaged climbing arrester systems must not be used.
- Clean the guided type fall arrester before and after each use to remove any dirt (see p. 18)
- Only the manufacturer may make changes to the climbing arrester system.
- Components may only be replaced with the written consent of the manufacturer.

- With a mass of 100 kg and a situation of fall factor 2 (worst case condition), the required clear height under the feet of the user is at least 2 m.
- Observe country-specific and regional rules and regulations.



#### DANGER

Observe hazards and possible impairment of the function by the effects of sharp edges, temperatures, chemical substances, electrical conductivity, cuts, abrasion, UV light and other climatic conditions.

### Use

- Use fall arrester only with full body harness according to DIN EN 361 or ANSI/ASSE Z359.11
- Check the adjustment and fit of the full body harness. Do not use loose-fitting full body harnesses.
- If the belt comes loose during ascent or descent, it must be readjusted by a secured person.
- Only use the front fall arrester eyelet for securing.
- Do not climb up and down hands-free.
- Do not bring the guided type fall arrester into latching position by your own intervention.
- When descending, do not assume a supine position to prevent the pawl from engaging.
- Holding the sleeve or activation the release function during ascent or descent could hinder the safe operation of the braking mechanism and should be done only from a safe position where there is no risk of a fall.
- Only enter and exit the climbing arrester system from a position where there is no danger of falling.
- Hook the carabiner hook of the belt element directly (without rope, intermediate connector, etc.) into the front eyelet on the safety harness of the fall arrester.
- External influences (environmental/ weather conditions) in which safe climbing in the climbing arrester system

cannot be guaranteed must be observed

- The horizontal distance A (length of the connection linkage supplied with the fall arrester) between the front of the guide and the force application point of the connector intended for attachment to the safety harness is 27 cm.
- Do not shorten, extend or modify the connection linkage length.

### Accident prevention regulations

Regional regulations for Europe must be observed. For Germany, the accident prevention regulations of the employers' liability insurance association BGI A 1 and guidelines for the use of personal protective equipment apply.

During installation, the valid accident prevention regulations and instruction sheets of the DGUV must be observed, e.g.:

- DGUV-I 208-032 (previously BGI/GUV-I 5189)  
Selection and use of fixed ladders.
- DGUV-I 201-014 (previously BGI 691)  
Information for retrofitting step-iron and fixed ladder gangways with climbing arrester systems on chimneys.
- DGUV-R 112-119 (previously BGR/GUV-R 199)  
Rescue from heights and depths with personal fall equipment. DGUV-R 112-198 (previously BGR/GUV-R 198)  
Use of personal protective equipment against falls from a height
- DGUV-R 103-007 (previously BGR 117)  
Step gangways for containers and enclosed spaces

### Provisions for emergency (rescue)

- National regulations in other countries and states must be observed, e.g. for the United States Of America - Occupational Safety and Health Standards 1910.140 Personal fall protection systems.
- For the rescue of fallen persons suspended in the climbing arrester system, the fixed ladder or the climbing rail may be used as an anchor point for the rescue.

- The fixed ladder and its attachments must be visually inspected for obvious damage before rescue to ensure suitability for rescue.
- If possible, select attachment points in the area of an attachment point of the fixed ladder.
- Attachment to only one rung is not permitted.
- Belt slings attached to the rail (DIN EN 795 - type B), for example, can be used as a stop device.  
Make sure that the attachment point is sufficiently stable for the load that occurs.  
Fasten belt slings to the attachment point with anchorage stitch.
- During the rescue, it is recommended that the rescuer additionally secures himself/herself with the climbing arrester device.
- Wire rope guides must not be used for slinging.
- Employees must be trained and instructed for rescue operations. Training is offered by the employers' liability insurance association or manufacturers, among others.
- Further information on rescue with personal protective equipment can be found in DGUV-R 112-119 and DGUV-I 208-032.

## Assembly

### General

Installation on buildings from bottom to top.

Installation in shafts from top to bottom.

To ensure the proper function of the guided type fall arrester and to prevent contact corrosion, arrester rails from MUNK GmbH are made of hot-dip galvanised steel, aluminium or pickled and passivated stainless steel.

For easy insertion and removal of the guided type fall arrester attach the lower end of the arrester rail approx. 0.80 m - 1.00 m above the standing space. Install a rail stop (end guard) at the top and bottom end.

Attach a fastening at each end of the

arrester rail and at each arrester rail catch (Fig. 1, 2 and 3).

Attach a notice sign at the entry point of the guided type fall arrester or step-irons at visible height next to the arrester rail.

Do not install the climbing arrester system in a highly corrosive atmosphere (e.g. swimming pool) without special protective measures.

To avoid stress corrosion cracks, special control measures must be taken or compatibility must be demonstrated.

When installing the arrester rail, observe ambient conditions (e.g. aggressive environments).

Use only approved equipment elements and combine them in such a way that there is no danger to the user and the climbing arrester system.

Attach a warning notice to the building structure where the safety distance (see page 4) is clearly visible to the user.

All connections must be permanent and all bolts and nuts must be secured against self-loosening. Only use the screws and fasteners supplied.

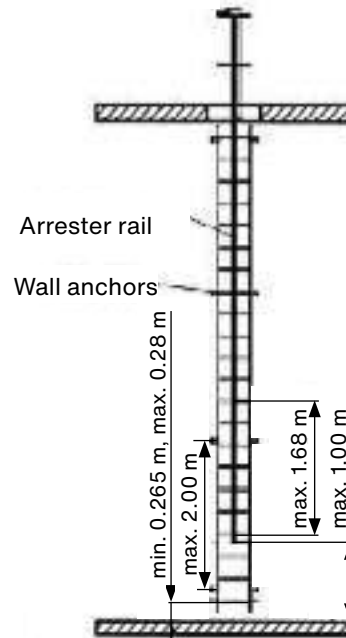

Fig. 4  
Shaft ladder with arrester rail

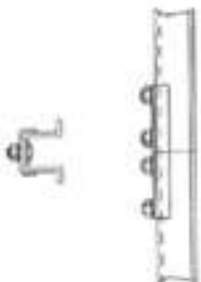

Fig. 1  
Connection  
Arrester rail

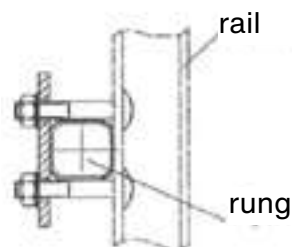

Fig. 2  
Attachment to the  
ladder rung rail

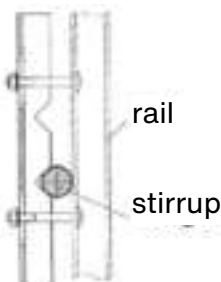

Fig. 3  
Securing on the step-iron

## Safety regulations for installation

The construction/supporting structure (steel structures) and the subsoil (concrete or stone) must have sufficient load-bearing capacity. The sufficient load-bearing capacity must be checked by a structural engineer before installation.

For anchor fastening, the requirements according to section "Anchors and wall fastenings", see page 11 must be observed.

The valid accident prevention regulations must be observed.

## Fixing the ladder to the building or in a shaft

When fastening a ladder to a building or in a shaft and when using the climbing arrester system of MUNK GmbH on longer ladder systems, the wall anchors must be installed at a distance of equal to or less than 2.00 m in accordance with the applicable standards and regulations and the corresponding specifications in the manufacturer's installation instructions (Fig. 5).



Fig. 5  
Arrester rail mounted on the rungs of a fixed ladder or shaft ladder.

The sufficient load-bearing capacity must be checked by a structural engineer before installation.

For shorter ladder systems, the ladder must be fixed to the ground using foot plates.

An increased number of wall anchors or fixing points must be provided.

At least 4 anchor points are required for wall anchors for dowelling or bricking in, taking into account the impact force of 6 kN for B25 concrete.

## Fixing the arrester rails to the rungs

If ladders other than those from MUNK GmbH are equipped with the MUNK GmbH arrester system, DGUV-I 201-014 must be observed.

The arrester rails are usually arranged in the middle of the ladder. The individual partial lengths of the arrester rails do not have to be assigned to correspondingly long ladder sections.

Attach the arrester rails to the ladder rung (Fig. 4) at intervals of no more than 1.68 m, but at least 4 attachment points for shorter ladder lengths.

Place a label (order no. 019007) on or near the fixed guide so that proper alignment during use, model and type designation of the guided type fall arrester and maximum number of users can be identified.

## Mounting the arrester rail on step-irons

Check that the step-irons and their attachments to the object are in perfect condition or that the impact force of 6 kN can be absorbed.

Fastening the arrester rail to the centre of the step iron is only permitted if the regulations from DGUV-I 201-014 are observed.

The remaining contact area on each side must be at least 85 mm.

The arrester rail must be attached to every third step iron. The arrester rail must be installed to the right or left of the step irons of the wall anchors if the step width is less than 85 mm.

Follow the instructions on page 15.



### DANGER

#### Danger of falling

- Only use the front catching eyelet of the full body harness according to DIN EN 361 or ANSI/ASSE Z359.11
- Under no circumstances use the lateral holding eyelets.
- Do not use additional connectors.



### NOTICE

Fix the climbing protection rail using wall anchors (Fig. 8 and 9) at intervals of 1.40 m, but at least 2 fixing points for smaller intervals.



**NOTICE**

For double step-irons, the arrester rail must be arranged in the middle if the space between the step irons is equal to or greater than 90 mm (Fig. 7).

The ladders as well as the step-irons must have sufficient load-bearing capacity. Regional regulations for European countries must be observed.

The sufficient load-bearing capacity must be checked by an expert before installation.

All attachments to the ladder rungs or step irons must be capable of absorbing a static vertical impact force of 6 kN.

For Germany: The sufficient load-bearing capacity (according to DGUV-I 201- 014 for the retrofitting of step irons and fixed ladder gangways with climbing arrester system) must be checked by a structural engineer. Anchors and wall fastenings

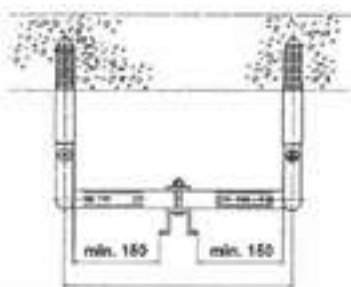

Fig. 6  
Mounting the arrester rail on step irons

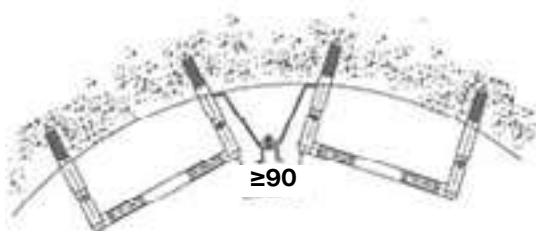

Fig. 7  
Mounting the arrester rail between step irons



Fig. 8  
Rigid wall anchor



Fig. 9  
Adjustable wall anchor

The anchors must be selected according to the substrate.

The anchors used in accordance with the relevant requirements shall comply with the provisions of the building inspectorate. The anchors must have a valid approval certificate for use

- in Europe, (ETA - European Technical Approval),

or

- from DiBt (German Institute for Structural Engineering).

The construction/supporting structure (steel structures) and the subsoil (concrete or stone) must have sufficient load-bearing capacity. The sufficient load-bearing capacity must be checked by a structural engineer before installation.

When selecting anchors, the load specifications of the individual brackets must be observed. Please contact an anchor manufacturer regarding the selection of anchors.

Observe the regulations of the anchor manufacturers when fixing with anchors. Observe the accident prevention regulations.

## Platforms (optional)

Maximum distance between the resting platforms with a total climbing height of more than 10 m:

- every 10 m
- every 25 m when used exclusively by trained persons (e.g. chimneys, antenna systems)

According to DIN EN 18799-1/-2, a trained person is demonstrably suitable, experienced and regularly instructed for the use of the climbing arrester system

The installation is possible on every rung.

During use, the user usually remains connected to the climbing arrester system and thus secured. If it is necessary to release the safety catch, the user must first secure himself against falling in some other way (e.g. double-strand slinging).

You can climb past platforms unhindered.

For use, the tread is folded with the foot from back to front.



Fig. 10  
Platform arrester rail

## End guards

Both end guards meet the requirements type A and type B according to DIN EN 353-1.

## Detachable end guards

Detachable end guards (see Fig. 11) prevent unintentional exiting of the climbing arrester system. Intentional exiting is possible by lifting the catch. The climbing arrester system may only be exited when the person climbing has reached a stand or workplace secured against falling.

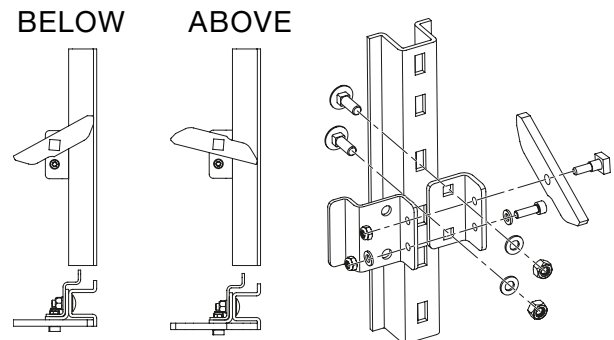

Fig. 11  
Detachable end guards for arrester rails

## Fixed end guards

Fixed end guards prevent exiting the climbing arrester system at the end of the climbing distance and at flanks.

All end guards must be installed before initial use.



### NOTICE

End guards and locks must not be removed!



### CAUTION

#### Danger of accidents

When using GÜFA 5/Flexx on an existing climbing arrester system, the end guards must be checked and new end guards installed if necessary.

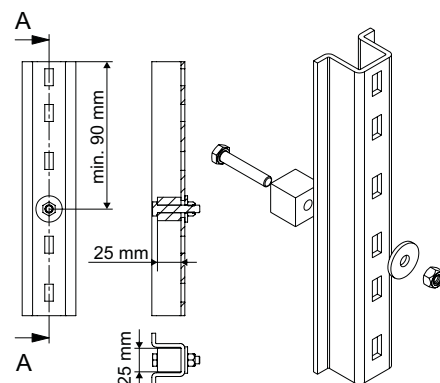

Fig. 12  
Fixed end guard arrester rail

## Single-rail ladder on building or shaft

When attaching a single-rail ladder to a building or in a shaft, the wall anchors must be installed at a distance equal to or less than 1.40 m. National regulations or customer requirements may deviate from this (e.g. German Federal Postal Service: 1.12 m).

For shorter ladder systems, the single-rail ladder must be fixed to the ground using base plates. An increased number of wall anchors or fixing points must be provided.

In the case of wall anchors for anchoring or masonry installation and taking into account the impact force of 6 kN, at least 2 fixing points are required for B 25 concrete.

## After installation



### DANGER

#### Danger of accidents

Before use, the climbing arrester system must be checked for the following points.

- Arrester rails or the single-rail ladder are correctly aligned.
- All screws are correctly mounted or tightened.
- All required rail stops are properly installed.
- The rail stops and platforms work.
- Damaged surfaces are repaired.
- All notice signs are attached.

## Inspections

### General

Regular inspections are necessary, the safety of the user depends on the effectiveness and durability of the equipment.

The employer must have the climbing arrester system and the safety harness inspected for perfect condition by a competent person in accordance with the statutory regulations, the frequency of use, the environmental conditions and the operating conditions as required, but at least every 12 months, and in strict compliance with the manufacturer's instructions. The legibility of the product marking must also be checked.

## Inspecting the climbing arrester system



### NOTICE

Proof of this inspection must be provided.

The user must visually inspect his personal protective equipment for proper condition before each use.

The legibility of the marking must be checked each time it is used (Notice for visual inspection see page 20).

In case of complaints, the equipment must be taken out of use and tagged "UNUSABLE" immediately or undergo corrective maintenance in accordance with this manual before returning to service.

## Inspecting the safety harness



### DANGER

#### Life-threatening danger

For safety reasons, remove the equipment from use immediately if

- there is any doubt as to its safe use, or
- if the equipment has been stressed by a fall.

Do not use the equipment again until a competent person has agreed in writing.



### NOTICE

Altering: Renew energy absorber every 10 years,

except for energy absorbers that in the low-temperature range (e.g. cold stores) are used.

These must be renewed every 6 years.

See date of manufacture energy absorber sticker

Storage times at the manufacturer/specialist dealer (Period of production until commissioning) of up to a maximum of one year can be added to the period of use.



**NOTICE**

Follow special instructions of the manufacturer.



**NOTICE**

Sort out or replace damaged climbing arrester systems and safety harnesses immediately. After repair and approval by the manufacturer they may be used again.

**Inspection before use**

The guided type fall arrester (Fig. 13 and 14) is functional if it meets the following criteria:

- The carabiner gate [A] must be freely movable and move automatically into the secure position.
- The energy absorber element [B] must have no cuts, places where rubbed off or otherwise damaged.
- The shackle [C] must be firmly closed and movable.
- The 4 rollers [D] must be available and freely movable.

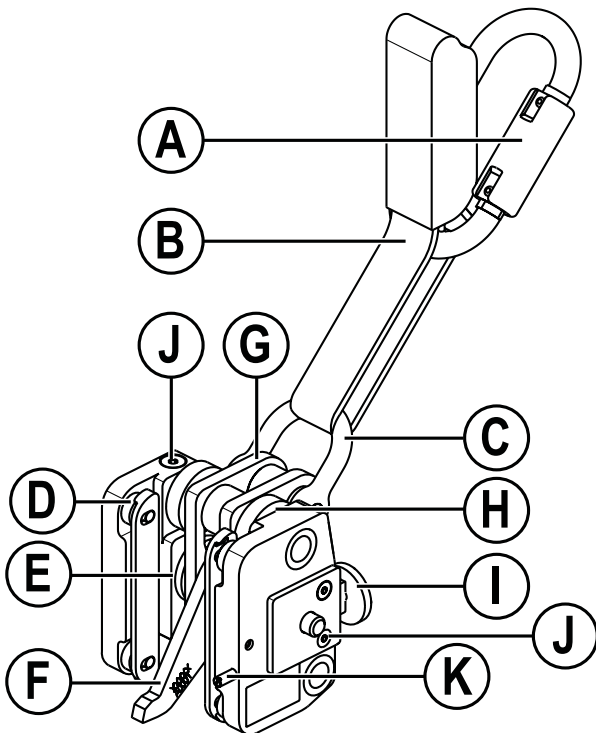

Fig. 13  
GÜFA Flexx safety-runner

- The spring [E] must not be broken and the spring function must be functional.
- The latching lever [F] must be movable and return to its initial position via the spring [E].
- The guide carriage [G] must be move freely and connected to the locking pin [F].
- The 10 retaining rings [H] must be present and must fit tightly on the bolts.
- GÜFA Flexx only (Fig. 13): It must not be possible to actuate the pressure plate (I) as long as the guided type fall arrester is not in the “arrow up” position.
- GÜFA Flexx only (Fig. 13): Without an actuated pressure plate (I) it must not be possible to pull the two side parts of the safety-runner apart.
- GÜFA Flexx only (Fig. 13): When the pressure plate (I) is actuated, the two tensioned side parts of the guided type fall arrester must be able to be pulled apart against the tension. Without pulling, the side parts must contract again.
- GÜFA Flexx only (Fig. 13): The 4 countersunk screws (J) must be present and firmly connected to the side parts.

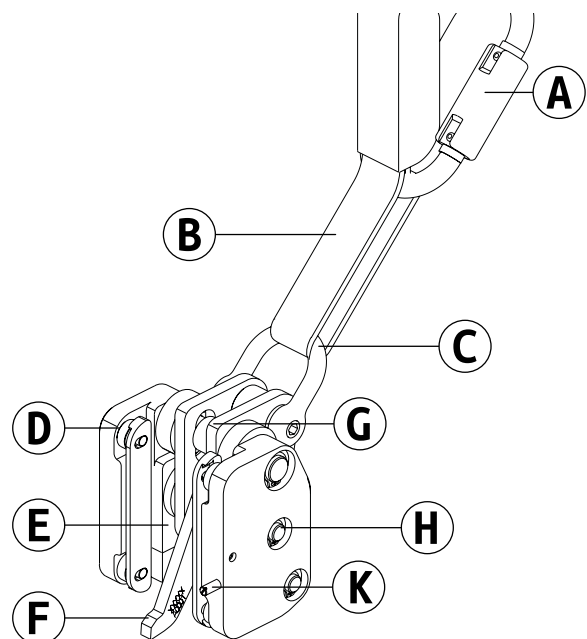

Fig. 14  
GÜFA 5 safety-runner

- The shaft screw of the insertion safety pin (K) must protrude at least 8 mm.

The arrester rail (Fig. 15) is functional if the following criteria are met:

- Functional end guards are provided at all rail ends.
- Screws of the end guards are tightened and complete.
- End guards are free from corrosion.
- The arrester rail [A] must not show any deformations.
- The arrester rail [A] must be free from corrosion.
- Catch [B] of the arrester rail [A] must not be offset.
- Rail connectors [C] must be firmly and completely screwed down.
- Marking available on the rail.
- Weld seams (if any) have no cracking.
- The arrester rail [A] is firmly and completely mounted.



#### NOTICE

To check the ladders, please also use our inspection sheet for fixed ladders below:

<https://www.munk-group.com/de/wissen/downloads>

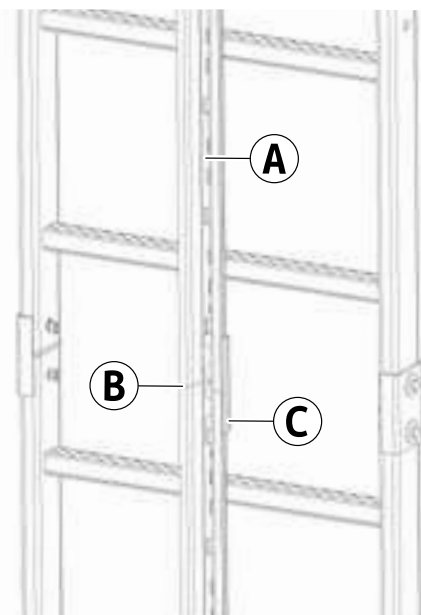

## Use of the guoded type fall arrester



#### DANGER

##### Danger of accident

Always observe the safety regulations on page 7.

### End guards

All points on the arrester rail where the safety-runner could unintentionally detach from the arrester rail and there is or could be a danger of falling must be provided with end guards.

### Entry at the beginning of the arrester rail

The guided type fall arrester must be inserted at the end of the arrester rail with the orientation “arrow pointing upwards”. Attention must be paid to proper insertion.

A functional test must be carried out at this point. Hold the guided type fall arrester by the carabiner and let it fall under its own weight. Hold the guided type fall arrester in your hand during the test without affecting the falling. Climbing up the ladder or step-irons can now be done safely.



#### DANGER

##### Danger of falling

Within the first 2 m the user may not be protected against hitting the ground. Particular caution is required when ascending and descending.

Fig. 15  
Ladder with arrester rail GÜFA

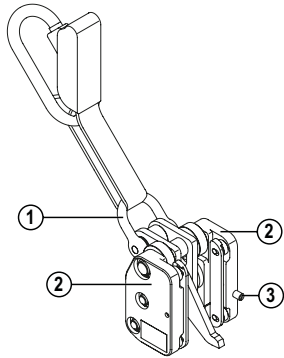

Fig. 16 guided type fall arrester (GÜFA 5)

1. Hold the guided type fall arrester on the shackle (1) and base body (2) with a slight downward pull and guide it into the arrester rail in the guide direction.
2. The shaft screw (3) prevents incorrect insertion into the arrester rail (Fig. 16).
3. When the guided type fall arrester reaches the type A or type B end stops (Fig. 17), the safety-runner is prevented from leaving the arrester rail unintentionally upwards or downwards.
4. Attach the carabiner hook of the guided type fall arrester to the eyelet on the full body harness of the fall arrester according to DIN EN 361.

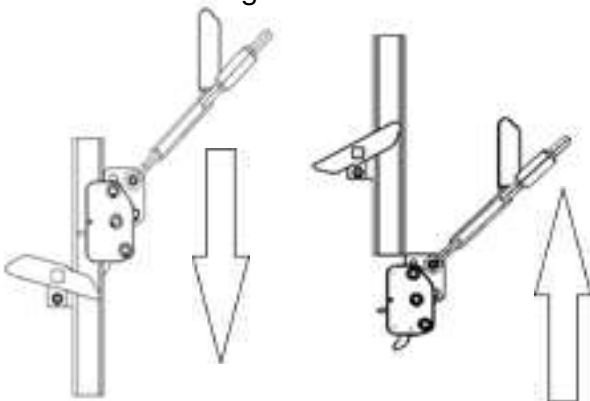

Fig. 17 Entering the climbing arrester system

### Exit at the beginning of the climbing arrester system

1. From the secured position, hold the guided type fall arrester on the shackle (1) and on the base body (2) and swivel the lever of the end stops against the direction of action (Fig. 18) so that the guided type fall arrester can pass over the position of the end stops and be guided out of the arrester rail.

2. Unhook the carabiner hook of the guided type fall arrester from the eyelet on the full body harness of the fall arrester.

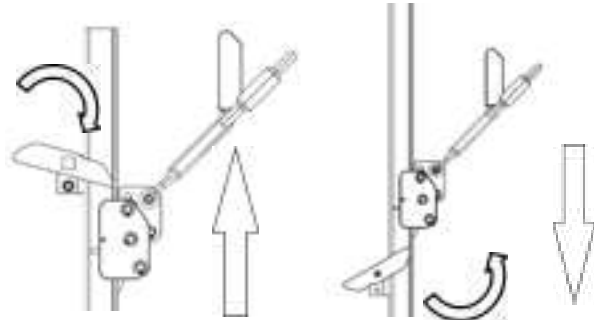

Fig. 18 Exiting the climbing arrester system

## Operating instructions and training

For the use of personal protective equipment (PPE) against falls from a height, the employer must draw up operating instructions containing all the information required for safe use, in particular the dangers according to the hazard assessment, the behaviour when using the PPE and any defects found.

A plan of rescue operations must be in place, taking into account all possible emergencies at work and have available the means at hand to implement it when the system is in use..

PPE users must be trained in accordance with the operating instructions. Instruction must be given at least once a year, more often if necessary.

If the climbing arrester system (or part of it) is resold in another country, the reseller must provide the instructions for use, maintenance, periodic inspection and repair in the local language.

The company to which the user belongs is responsible for preparing the documentation and entering the required information.

The user shall determine their fully equipped weight and ensure it is within the capacity range set.

Climbing ladders with hoops or cages or that are located in confined areas may reduce the effectiveness of the fall arrester system. An appropriate clear climbing path must be maintained.

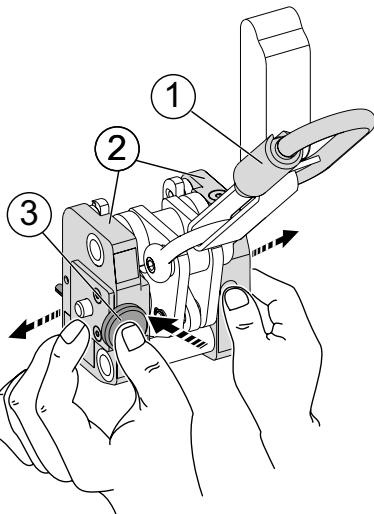

Fig. 19  
Spreading the GÜFA Flexx

### Entry along the course of the arrester rail (GÜFA Flexx only)

The GÜFA Flexx guided type fall arrester also allows access along the course of the arrester rail through an extension mechanism.

1. For the functional inspection, hold the GÜFA Flexx by the carabiner (1) and let the safety-runner hang by its own weight. The latching lever must then move towards the main body (2).
2. Attach the carabiner hook of the guided type fall arrester to the eyelet on the full body harness of the fall arrester according to DIN EN 361.
3. Hold the base body (2) with both hands in the "up arrow" orientation.
4. Press the pressure plate (3) with the thumb of your left hand. Pull the base



#### NOTICE

Pressure plate (3) can only be operated in the "arrow up" direction.

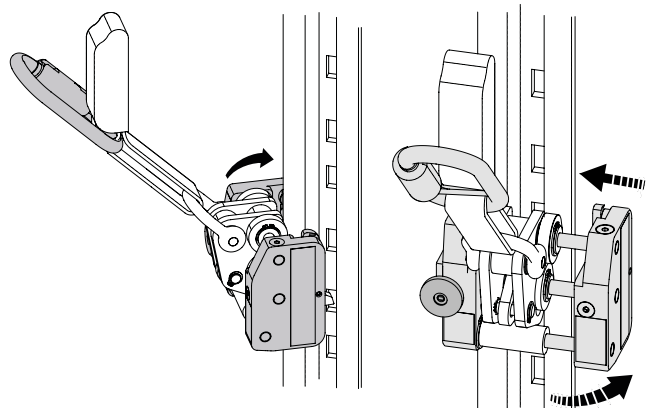

Fig. 20  
Insert GÜFA Flexx into the arrester rail

- body (2) apart with both hands.
5. Hook the base body (2) onto the left side of the arrester rail.
6. Fold the base body (2) over the right side of the arrester rail.
7. Release the pressure plate (3).
8. Press the base bodies (2) together with both hands.



#### DANGER

##### Danger of falling

The guided type fall arrester must be completely engaged. The pressure plate (3) jumps automatically to the home position.

The side panels now completely enclose the running rail of the arrester rail.



**DANGER**

**Danger of falling**  
Exit the climbing arrester system only from a secured position.

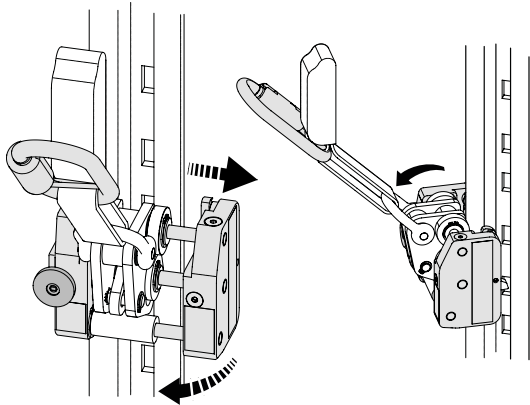

Fig. 21  
Remove GÜFA Flexx from the arrester rail

**Exit along the arrester rail (GÜFA Flexx only)**

1. Hold the main body (2) with both hands.
2. Use the thumb of your left hand to operate the pressure plate (3). Pull the base body (2) apart with both hands.
3. Pull the extended base body (2) to the right of the arrester rail.
4. Pull the left side of the base body (2) off the arrester rail.
5. Unhook the carabiner hook of the guided type fall arrester from the eyelet on the full body harness of the fall arrester.

**Maintenance, Storage, clea-**



**NOTICE**

Maintenance means maintaining the safe function through preventive measures such as cleaning and appropriate storage.

**ning, decommissioning, dismantling and disposal**

**Maintenance, Storage and cleaning of the Guided type fall arrester**

After climbing, the guided type fall arrester with the strap element must be removed from the arrester rail.

Check the climbing arrester system for damage.

The guided type fall arrester after the climbing:

- clean (but not with aggressive substances such as acids). In case of heavy soiling, clean, warm tap water with standard soap can be used. Then dry with a clean cloth and leave to air dry completely (but not on the heater, fire or in direct sunlight).
- store and transport in a dry, clean, not too warm place, free from vibrations and sharp edges.
- Protect from direct exposure to light and UV radiation as far as possible.
- Do not store near heaters, fire or other sources of heat.

If the guided type fall arrester gets wet, dry it (but not on a heater, fire or in direct sunlight).

**Decommissioning, dismantling and disposal**

The packaging must be disposed of in accordance with the applicable regulations and statutory provisions.

The packaging and the product are not toys. There is a danger of suffocation when playing with the packaging.

At the end of its serviceability, parts of the climbing arrester system must be safely removed from use and disposed of in accordance with the applicable regulations. As aluminium is a high-quality material, it should be recycled.

For detailed information, please contact your local authority.

## Warranty and liability

The scope, period and form of the warranty are recorded in the terms and conditions of sale and delivery of MUNK GmbH. For warranty claims, the operating instructions valid at the time of delivery are always decisive.

Beyond the terms and conditions of sale and delivery, the following applies:

No liability will be assumed for personal injuries or property damage that have arisen due to one or several of the following reasons:

- improper use
- ignorance or non-compliance with these operating instructions,
- improper installation and use of the product,
- improperly performed repairs,
- Use of other than original replacement parts,
- Use of the system with defective components,
- inadequately qualified or insufficient assembly and user personnel,
- unauthorised structural modifications,
- Disaster situations due to the effect of foreign matter and excessive force.

The operator must ensure on its own responsibility that the safety provisions are adhered to and that the device is used for its intended purpose.

Please note that the distribution or reproduction of these operating instructions or the disclosure of its contents is only permitted with the explicit consent of MUNK GmbH.

Violations of the statements given above shall result in an obligation to pay compensation for damages.

MUNK GmbH retains the copyright for these operating instructions.

MUNK GmbH

Günzburg, 17/01/2022

## Copyright

These instructions apply to all products whose material numbers are listed on the title page.

©2022 MUNK GmbH

All rights to this document are reserved by MUNK GmbH. This document may not be copied, reproduced or translated in whole or in part without the written permission of MUNK GmbH.

The document is intended for the user of the product described and may only be passed on to the purchaser if the product is resold.

Subject to technical modifications and errors. No claims to specific properties of the product can be derived from the contents of these operating instructions.

## Documentation

### Annual inspection

Inspection criteria	Yes	No
<b>1. Carabiner hooks</b>		
unsoiled		
undamaged		
Safety lock intact		
<b>2. Energy Absorber</b>		
no older than 10 years (6 years when used in low temperature range) +1 year storage time		
undamaged		
no tears		
<b>3. Shackles</b>		
unsoiled		
undamaged		
bolts firmly screwed on		
red sealing wax on shackle and bolt connected together		
<b>4. Rollers</b>		
unsoiled		
undamaged		
move freely		
<b>5. Spring</b>		
unsoiled		
undamaged		
not broken		
<b>6. Latching lever</b>		
unsoiled		
undamaged		
move freely		
<b>7. Guide carriage</b>		
unsoiled		
undamaged		
move freely		
<b>8. Circlips</b>		
available (GÜFA 5: 10 pcs.; GÜFA Flexx: 9 pcs.)		
securely mounted on the bolts		
<b>9. Arrestor rail</b>		
no corrosion		
no damages / deformations		
<b>10. End guards</b>		
no corrosion		
no damages / deformations		
fully functional		

Inspection criteria	Yes	No
<b>11. Pressure plate, position "arrow upwards" (only GÜFA Flexx)</b>		
Pressure plate can be actuated		
Side pieces can be pulled apart		
Side pieces move together automatically		
<b>12. Pressure plate, position "arrow downwards" (only GÜFA Flexx)</b>		
Pressure plate blocked when actuated		
<b>13. Pressure plate (only GÜFA Flexx)</b>		
unsoiled		
no damages / deformations		
<b>14. Countersunk bolts (only GÜFA Flexx)</b>		
available (5 pcs.)		
securely attached with the side pieces		
<b>15. Shaft screw of the insertion safety pin</b>		
Shaft screw protrudes at least 6 mm		
<b>16. Damages detected (previous columns answered with "No")</b> (Any damage detected must also be entered in the "documentation of the equipment".)		
<b>17. Identity of the system site</b>		
<b>18. Measures implemented</b>		
	<b>Yes</b>	<b>No</b>
Destruction carried out		
Repair performed		
<b>19. Slide mechanism is approved</b>		
inspection Date		
Signature		
<b>20. name of the competent person conduction the inspection and the results of that inspection</b>		
<b>21. Next inspection on</b>		

## Documentation of the equipment

Product		Type and model / Identification	
Brand name		Dealers	
Address			
Phone and Fax nos.		Email	
Sales date		Date of initial use	
Range of application			
Other significant information			

## Documenattion for the annual inspection

Date	Reason for the treatment (regular check or repair)	Damages detected, repairs performed and other essential information	Name and signature of the competent person	Date of the next periodic review

## Assembly protocol

### Assembly protocol (to be filled out by the installer):

Manufacturer:  
MUNK GMBH  
Rudolf-Diesel-Strasse 23  
89312 Günzburg  
Germany

Type of climbing arrester system: \_\_\_\_\_

Year of manufacture of the climbing arrester system: \_\_\_\_\_

Installed on:

- Fixed ladder                       Shaft ladder  
 Step iron gear                       MUNK single-rail ladder  
 Mast Ladder

Installed on: \_\_\_\_\_

Installed by: \_\_\_\_\_

Name of the installer: \_\_\_\_\_

Signature of the installer: \_\_\_\_\_

## EU Declaration of Conformity

The manufacturer or his authorised representative established in the Community

**MUNK GMBH**

**Rudolf-Diesel-Strasse 23**

**D-89312 Günzburg**

hereby declares, that the

**Guided type fall arrester including fixed guide**

**Type: GÜFA**

and

**Type: GÜFA Flexx**

both conform with the provisions of Regulation 2016/425/EU and with the standard DIN EN 353-1:2018 and are identical to the PPE which were the subject of

**DEKRA Testing and Certification GmbH**

**D-44809 Bochum**

**Identification no.:0158**

issued EU - type examination certificate **No.: ZP/B051/20**,

which, on the basis of Regulation 2016/425/EU, undergo internal production control with supervised product testing according to module C2 under the supervision of the notified body

**DEKRA Testing and Certification GmbH**

**D-44809 Bochum**

**Identification no.:0158**

Günzburg, 17.01.2022

MUNK GmbH

Rudolf-Diesel-Strasse 23

89312 Günzburg, Germany



Thomas Bichler  
Standards Representative

TRANSLATION

(1) **Type Examination Certificate**

(2) No. of the Type Examination Certificate: **ZP/B100/20**

(3) Product: **Fall Arrest Systems**  
Type: **GÜFA Floxx**

(4) Manufacturer: **Günzburger Steigtechnik GmbH**

(5) Address: **Rudolf-Diesel-Straße 23**  
**89312 Günzburg, Germany**

(6) The design of this product and any acceptable variation thereto are specified in the schedule to this Type Examination Certificate.

(7) The certification body of DEKRA Testing and Certification GmbH certifies that this product complies with the fundamental requirements of the standard listed under item 8 below. The examination and test results are set out in the report PB 20-134.

(8) The requirements of the standard are assured by compliance with

**ANSI/ASSP Z359.16-2016**

(9) This Type Examination Certificate relates only to the design, examination and tests of the specified product in accordance to the standard list. Further requirements of the Directive apply to the manufacturing process and supply of this personal protective equipment. These are not covered by this certificate.

(10) This Type Test Certificate is valid until 2025-06-24.

DEKRA Testing and Certification GmbH  
Bochum, 2020-06-25

signed: Kilsch  
Managing director

We confirm the correctness of the translation from the German original.  
In the case of arbitration only the German wording shall be valid and binding.

Managing director

Page 1 of 4 of ZP/B100/20

This certificate may only be published in its entirety and without any change.  
DEKRA Testing and Certification GmbH, Hohenstraße 15, 70372 Stuttgart, Germany  
Certification Body: Drexelstraße 3, 44801 Bochum, Germany  
Phone: +49 234 3696-400, Fax: +49 234 3696-401, DTC Certification Body@dekra.com

TRANSLATION

(1) **Type Examination Certificate**

(2) No. of the Type Examination Certificate: **ZP/B167/21** replaces ZP/B131/20

(3) Product: **Climbing ladder fall arrest systems**  
Type: **GLIFA 5**

(4) Manufacturer: **MUNK GmbH**

(5) Address: **Rudolf-Diesel-Straße 23**  
**89312 Günzburg, Germany**

(6) The design of this product and any acceptable variation thereof are specified in the schedule to this Type Examination Certificate

(7) The certification body of DEKRA Testing and Certification GmbH certifies that this product complies with the fundamental requirements of the standard listed under item 8 below. The examination and test results are set out in the report PB 21 101.

(8) The requirements of the standard are assured by compliance with

**ANSI/ASSE Z359.16-2016**

(9) This Type Examination Certificate relates only to the design, examination and tests of the specified product in accordance to the standard list. Further requirements of the Directive apply to the manufacturing process and supply of this personal protective equipment. These are not covered by this certificate.

(10) This Type Test Certificate is valid until 2026-11-08

DEKRA Testing and Certification GmbH  
Bochum, 2021-11-09

signed: Kilich  
Managing director

We confirm the correctness of the translation from the German original.  
In the case of arbitration only the German wording shall be valid and binding.

  
Managing director

Page 1 of 4 of ZP/B167/21 - 342422800

This certificate may only be published in its entirety and without any change.  
DEKRA Testing and Certification GmbH, Hanswerkstr. 15, 70865 Stuttgart, Germany  
Certification Body: Lindenstraße 3, 44801 Bochum, Germany  
Phone +49 234 3698-400, Fax +49 234 3698-401, GTC-Certification-Russia@dekra.com

## Safety. Made in Germany.

MUNK Günzburger Steigtechnik is a brand of the MUNK Group and is synonymous with premium quality for ladders, mobile scaffolding and special designs.



MUNK Günzburger Steigtechnik



MUNK Rettungstechnik

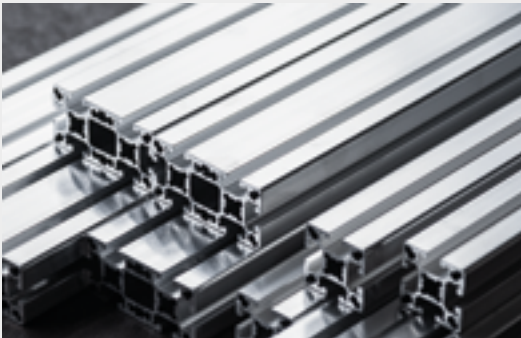

MUNK Profiltechnik



MUNK Service

MUNK GmbH | Rudolf-Diesel-Str. 23 | 89312 Günzburg  
Tel +49 (0) 82 21 / 36 16-01 | Fax +49 (0) 82 21 / 36 16-80 | [info@munk-group.com](mailto:info@munk-group.com)